

Field Adjustment of Current Transformer Ratio

The ratio of current transformers can be field adjusted to fulfill the needs of the application. Passing more secondary turns or more primary turns through the window will increase or decrease the turns ratio.

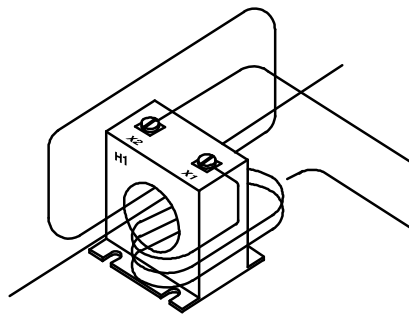

$$\text{ACTUAL TURNS RATIO} = \frac{\text{NAMEPLATE RATIO} - \text{SECONDARY TURNS ADDED}}{\text{PRIMARY TURNS}}$$

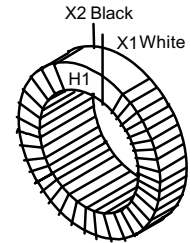

- Increasing the number of primary turns can only decrease the turns ratio. A current transformer with a 50 to 5 turns ratio can be changed to a 25 to 5 turns ratio by passing the primary twice through the window.
- The turns ratio can be either increased or decreased by wrapping wire from the secondary through the window of the current transformer.
- When using the secondary of a current transformer to change the turns ratio, the right hand rule of magnetic fields comes into play. Wrapping the white lead or the X1 lead from the H1 side of the transformer through the window to the H2 side will decrease the turns ratio. Wrapping this wire from the H2 side to the H1 side will increase the turns ratio.
- Using the black or X2 lead as the adjustment method will do the opposite of the X1 (white) lead. Wrapping from the H1 to the H2 side will increase the turns ratio, and wrapping from the H2 to the H1 side will decrease the turns ratio.
- Increasing the turns ratio with the secondary wire, turns on the secondary are essentially increased. A 50 to 5 current transformer will have a 55 to 5 ratio when adding a single secondary turn.
- Decreasing the turns ratio with the secondary wire, turns on the secondary are essentially decreased. A 50 to 5 current transformer will have a 45 to 5 ratio when adding a single secondary turn.
- Decreasing the turns ratio with the primary, accuracy and VA burden ratings are the same as the original configuration.
- Increasing the turns ratio with the secondary will improve the accuracy and burden rating.
- Decreasing the turns ratio with the secondary will worsen the accuracy and burden rating.