

Wire Mounted Current Indicator

CR45 Series MB45 Bracket

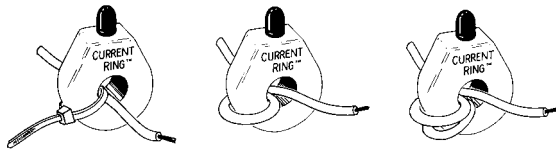
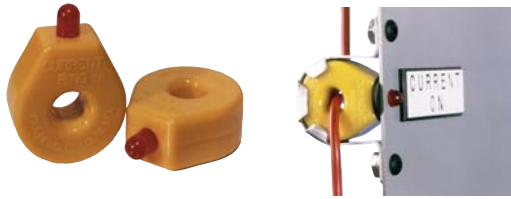

One-Wire Pass

Two-Wire Passes

Three-Wire Passes

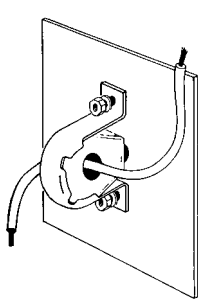

Panel Mount

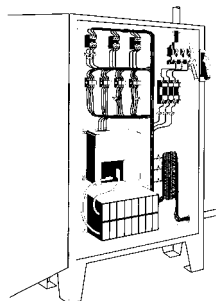

Load Center

PART NUMBERS

Part Number	LED Color	Turn On Point (1 pass)
CR45-R	Red	2.0 AAC
CR45-G	Green	2.5 AAC
CR45-B	Blue	2.0 AAC
CR45-W	White	2.0 AAC
CR45-Y	Yellow	2.0 AAC
CR45-A	Amber	2.0 AAC
MB45	Panel Mounting Bracket	

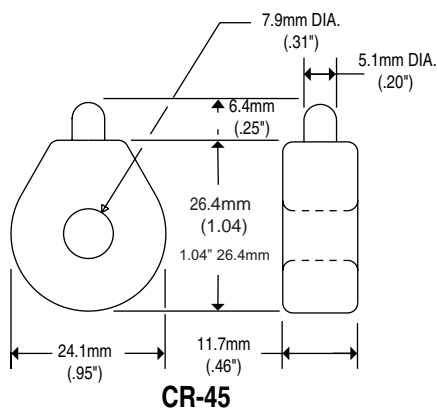

CR-45

The **CR45** Series, Wire Mounted Electrical Current Indicators provide an effective method of monitoring electrical current. The indicator is attached directly to a current-carrying wire. When the current exceeds the turn-on point, the LED will illuminate to indicate the presence of current.

Applications

- Monitor Status of Heater Elements
- Observe Remote Loads
- Indicate Phase Loss
- Monitor Motor Operation

Features

- Self Powered
- Red, Green, Blue, White, Yellow and Amber Indicators
- Easy to Install
- Supplied with a plastic wire tie
- Bright Yellow Case for Easy Identification
- Panel Mounting Bracket available

Specifications

- 100 AAC Max, 600 VAC Max rating
- Thermoplastic Case Material
- 14.2 g / 0.5 oz weight
- 50 - 1Khz Bandwidth
- 10°C to +85°C Operating Temperature
- Mounting Bracket Non-Magnetic Aluminum Material
- Weight 0.03 LBS.

Regulatory Agencies

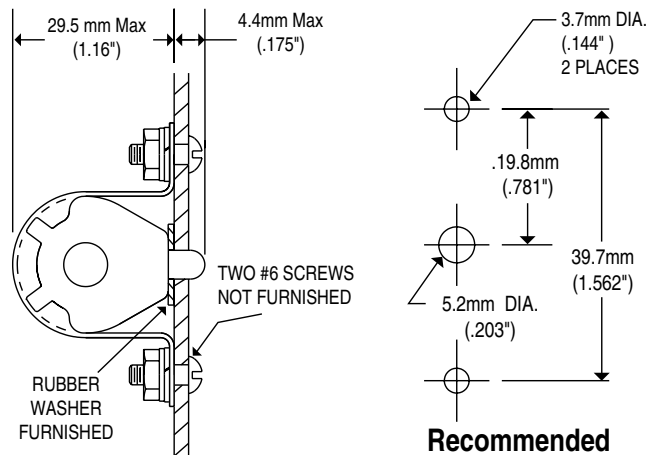

MB45

Recommended Mounting Hole Pattern



Another HUNTINGTON ELECTRIC Company

CR Magnetics, Inc. 3500 Scarlet Oak Blvd. St. Louis MO USA 63122 V: 636-343-8518 F: 636-343-5119

Web: <http://www.crmagnetics.com>

E-mail: sales@crmagnetics.com