

## APPLICATION SHEET AN4310-1

### Using the CR4310/11 Series Current Transmitter

The 4310 and 4311 series transducers are self-powered variable voltage devices that automatically adjust their DC voltage output to maintain a DC voltage that is proportional to the Average RMS Value of the AC current flowing through the window of the transmitter. The 4310 outputs 5VDC and the 4311 outputs 10VDC for full scale AC input current.

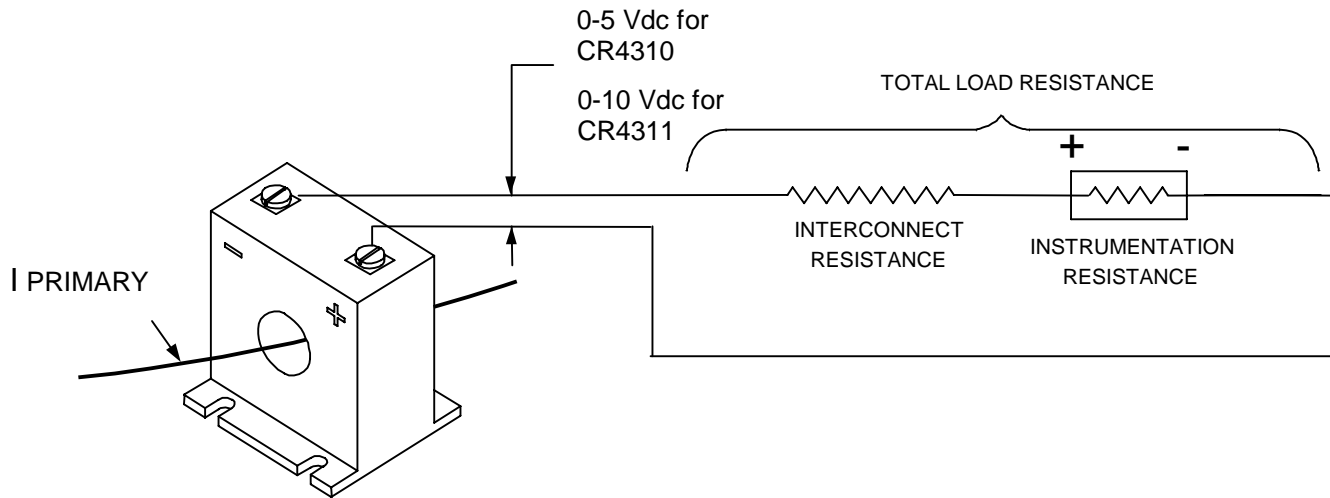

### TROUBLESHOOTING AND INSTALLATION NOTES

- Verify that the correct polarity is observed as shown. The 4310/11 series are polarity protected, so damage should not occur if connected in reverse polarity.
- Insure that the total loop resistance (instrument plus wire) exceeds the minimum load resistance for the range chosen. Most commonly, an instrument with a burden of 1 Meg ohms is chosen. If the total loop resistance is less than required, the transducer will not function according to published specifications.
- Twisted pair wire should be adequate for most applications but shielded/twisted pair wire with the shield grounded at the instrumentation end may be required for the most severe environments. Refer to the instrumentation installation manual for more details regarding interconnect requirements.
- The output is calibrated to be proportional to the Average RMS of the current primary at 60 Hz. Signals from devices such as SCR and variable speed drives will not produce an accurate indication of RMS current levels.
- The first step in troubleshooting would be to check the voltage across all of the components in the loop.
- Transducers may be mounted in close proximity to each other without concern for magnetic interaction.
- An external current transformer may be attached to the transducer for applications that require monitoring current levels above 200 AAC.