

APPLICATION SHEET ANCR4395-1

Motor Current Monitor Using the CR4395 Relay

The CR4395 current sensing relay can be used as an effective way to monitor the operational load of a motor. Overloading and underloading can be sensed from primary current levels to trigger alarms, lockouts, and indicators. The EH version (active above setpoint current) can be used for overload, and the EL version (active below setpoint current) for underload.

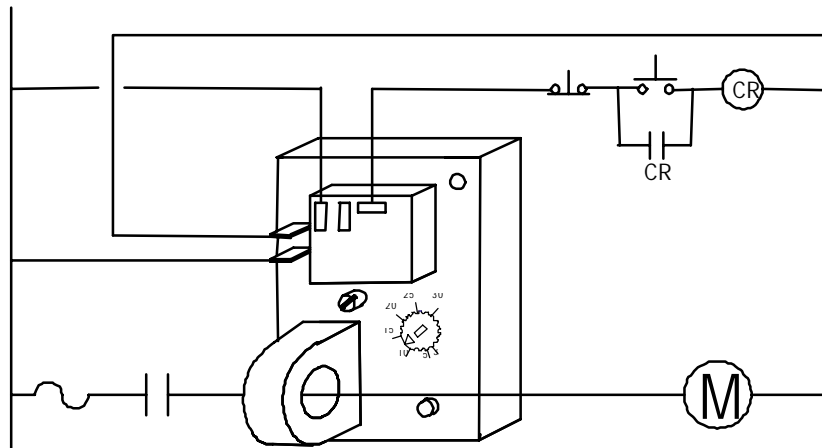

APPLICATION AND LIMITATIONS

- The CR4395 can be ordered with three time delay settings, A for .5 to 6 seconds, B for 2 to 20 seconds, and X for no delay. The EH option can utilize the time delay for preventing undesired activation during high motor startup currents.
- The time delay function can also be used for pulsed motor applications in the EL circuit. Here, activation of the relay will occur only if the current to the motor remains below the setpoint for longer than the delay period.
- Both the EH and the EL versions are available with the latching option. When tripped, the relay remains in the activated state until power is reset.
- The CR4395 comes standard with a mechanical relay that provides a Form C single pole contact. Other outputs such as transistor and triac switches are available as options. Typically, the mechanical relay is used to provide higher current switching for other motors and loads, and the solid state options are used to interface with digital and PLC circuitry, which eliminates switch bouncing.
- A combination of time delay setting and setpoint level can implement special indicator functions. Lower time delays, with properly chosen current trip levels can give an indication of motor bearing stress with the EH version. The EL version with longer delays and properly designed trip levels can be used for yield monitors in continuous process industries.
- The CR4395 is an effective tool in protecting and monitoring motors, however, **electrical fuses or other devices may be required for complete circuit protection.**