

## APPLICATION SHEET ANCR4730-1

### Using the CR4730 Series Voltage Transmitter

The CR4730 series are variable resistance devices that automatically adjust their DC series resistance to maintain a DC current that is proportional to the Average RMS Value of the AC voltage connected to the inputs of the transmitter. Since these are variable resistance devices, the 4-20mA loops must derive power from an external DC power supply.

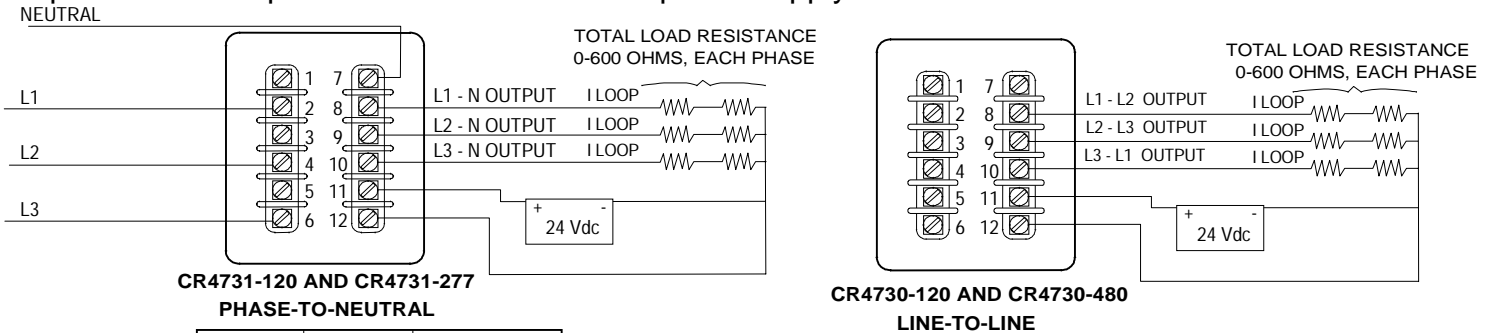

MODEL	RANGE IN VOLTS	CONNECTIONS L1 - L2 - L3
CR4730-480	360 TO 600	1 - 3 - 5
	180 TO 300	2 - 4 - 6
CR4730-120	90 TO 150	2 - 4 - 6

$$I_{\text{LOOP}} = \left[ \frac{\text{AC VOLTS}}{\text{FS}} \times 16 \right] + 4$$

### TROUBLESHOOTING AND INSTALLATION NOTES

- Verify that the correct polarity is observed as shown. The 4730 series are polarity protected, so damage should not occur if connected in reverse polarity.
- Insure that the total loop resistance (instrument plus wire) does not exceed 600 Ohms. Most commonly, an instrument with a burden of 250 Ohms is chosen. If the total loop resistance is greater than 600 Ohms the transducer will not function according to published specifications.
- Choosing connection wire with 22 gauge conductors or larger will minimize connection resistance on most applications. Twisted pair wire should be adequate for most applications but shielded/twisted pair wire with the shield grounded at the instrumentation end may be required for the most severe environments. Refer to the instrumentation installation manual for more details regarding interconnect requirements.
- Verify that the output of the DC supply is at least 24 VDC, with a current rating of 20 ma or greater per transmitter connected.
- The output is calibrated to be proportional to the Average RMS of the voltage at 60 Hz. Signals from devices such as SCR and variable speed drives will not produce an accurate indication of RMS voltage levels.
- Multiple loop powered transducers may be attached to the same power supply. Attach one side of the power supply common to all the transducers.
- The first step in troubleshooting would be to check the voltage across all of the components in the loop. At zero volts, the voltage across the instrumentation will be its burden resistance times .004.
- Transducers may be mounted in close proximity to each other without concern for magnetic interaction.