

# Using External Current Transformers with Other CR Devices

Many times, the application requirements do not allow using a single sensor such as a transducer or current sensing relay. The level of the current sensed may be too great, the size of the conductor may be too large, or the location of the sensor may not allow the placement of the transducer. In these cases, a two piece solution can be used, with a remote or external transformer chosen for capacity, size, or location, and a transducer or current sensing relay for input or control.

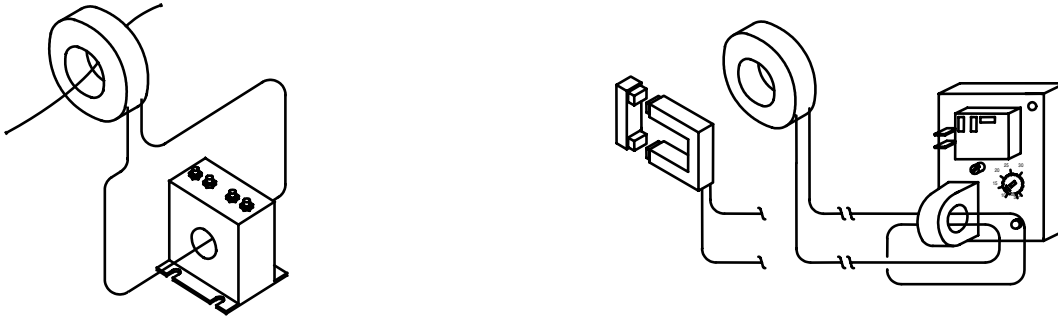

- Typically, a standard 5 amp secondary current transformer is selected. These transformers integrate easily with the 5 amp input transducers and transmitters (CR4300 class)
- The accuracies listed under the burden values are given in percent. These values are for a full scale reading. Percent accuracy means that the reading received from the transformer at the burden listed will be within the percentage given of ideal. Hence, a 50 to 5 turns ratio transformer with 50 Amps through the window will output 5 amps +/- 0.3% in the secondary into a 0.1 ohm burden. The current in the secondary will be somewhere between 4.985 and 5.015 amps.
- When the instrument connected gives the burden to the transformer in VA (volt-amps) the table can be used to determine accuracy. Since the transformer has a 5 amp secondary, using Ohm's Law, the impedance can be determined. A burden of 5 VA must be equal to the current squared times the impedance in ohms. Thus,  $5VA / (5 \times 5) = 0.2 \text{ Ohms}$ . The accuracy of this transformer-meter system would be 0.6%.
- If the impedance calculated or chosen falls between headings, use interpolation to determine accuracy.
- In general, the lower the burden, the higher the accuracy.
- It is critical to understand that the accuracy ratings are for a full scale reading. This accuracy will only be maintained from 10% full scale and up. Below this, and the accuracy worsens greatly. Always strive to select transformers so that the majority of readings will be within the 10 to 100% full scale range.

